

H: Optional HP adapter according to drawing 7W-900-

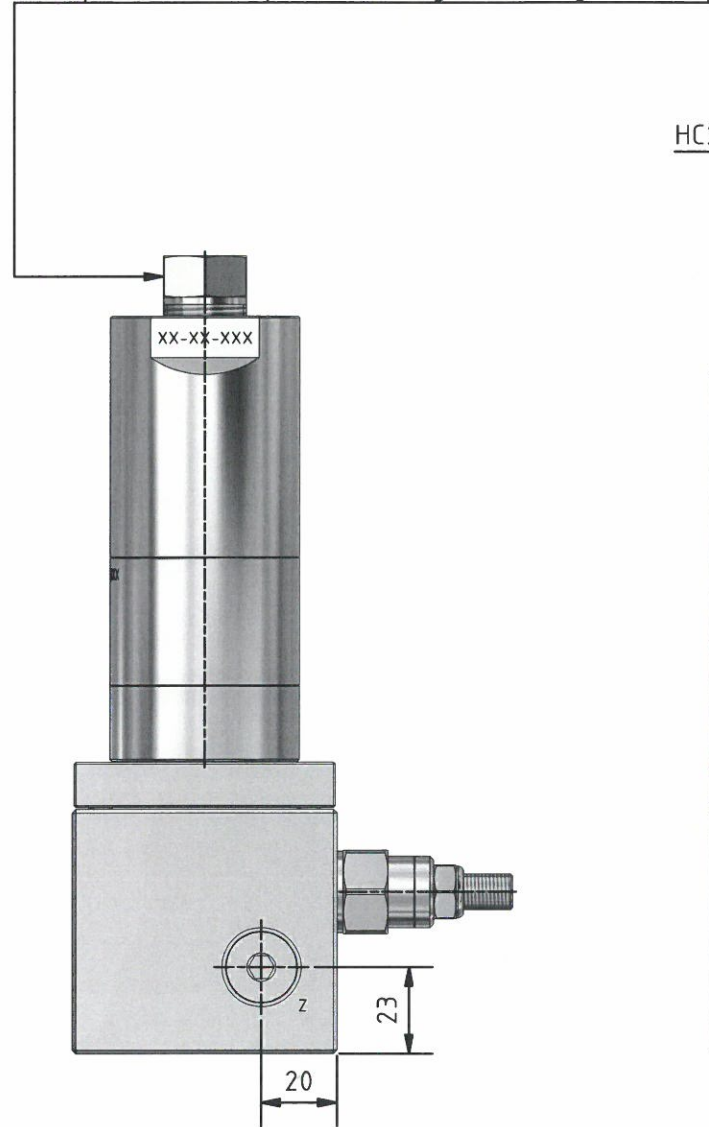

Hydraulic Booster HC7W- - -1

HC2W adapter plate

Pressure Reducing Valve
Cavity: 11A-3

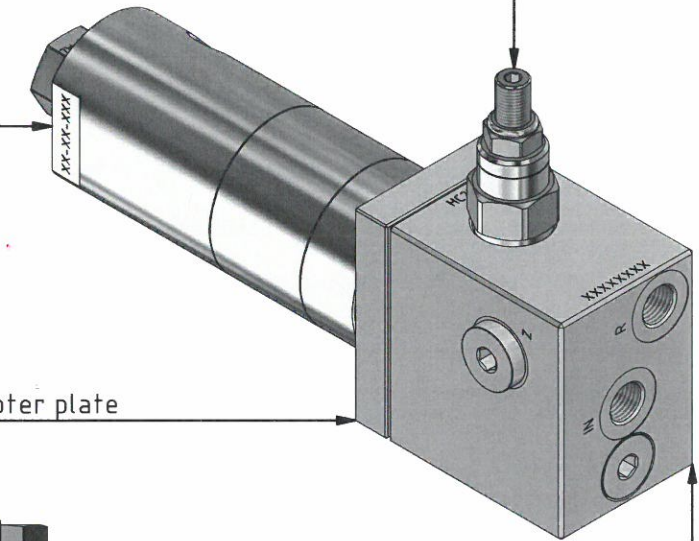

HC2W-CV2W-1 valve block



IN, R & Z: 1/4" BSPP

H: Drawing 7W-900-__

Function diagram: 0-624-__

Material		Stainless steel 316L		Issue	Material Code No.
Changes		Date	Name	Finish	
				Break all edges	
				Hardening depth	
				HV	
Designer	Brian Petersen	Scale	1 : 4	HC7W + HC2W-CV2W-1	
Approved by	<i>Leif Hansen</i>	Format	A3	Hydraulic Booster	
Date	16.03.2017			Assembly Drawing	
				<small>Confidential: Property of miniBOOSTER HYDRAULICS A/S Denmark Not to be handed over to, copied or used by third party.</small> 	
				Drawing No.:	0-392-00