

Pressure Reducing Valve
 Example: CP230-4B0AC0
 Cavity: C10-3

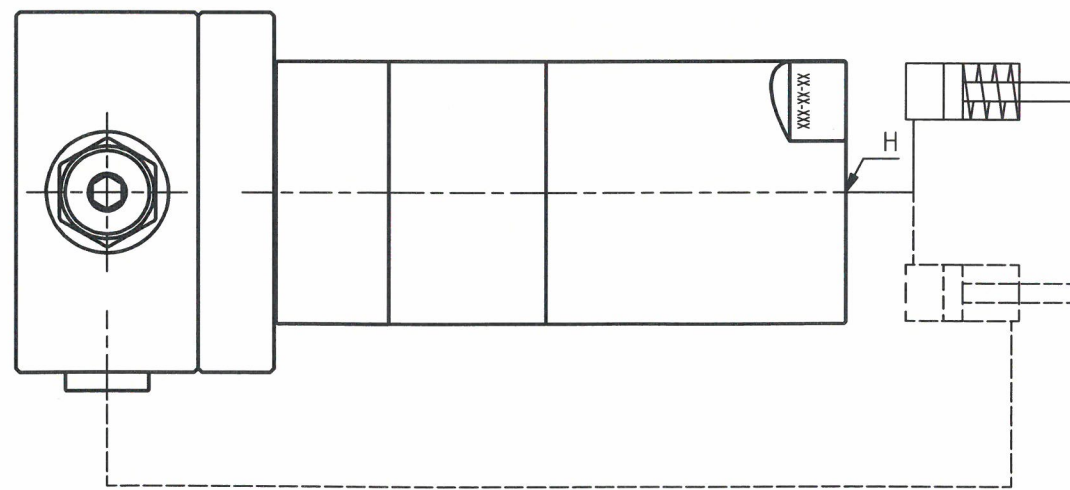
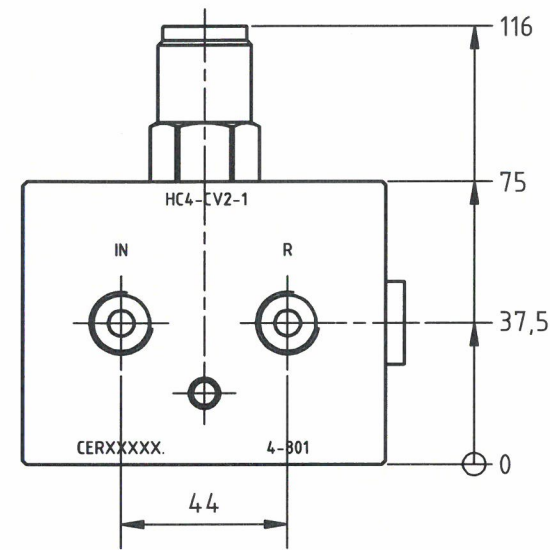
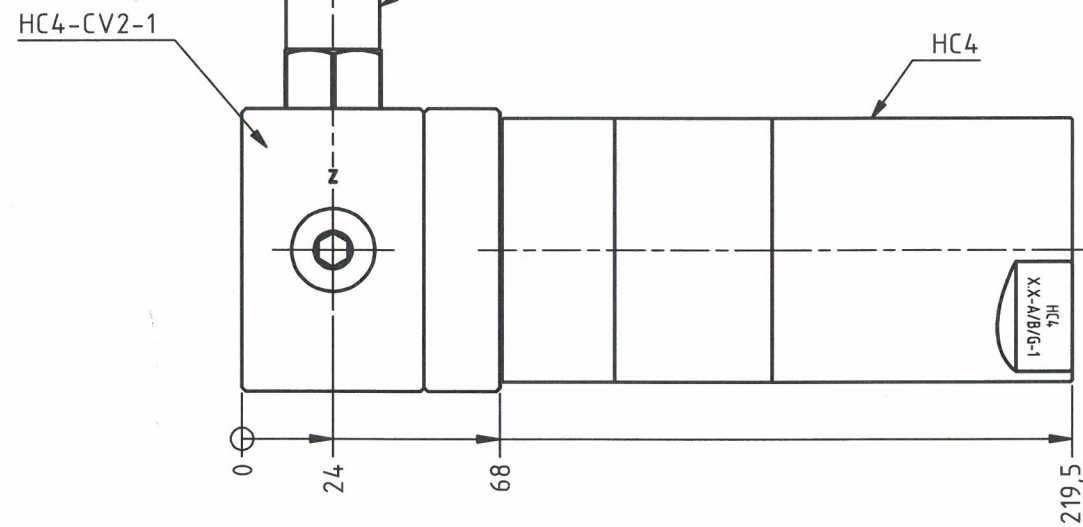

Connections:

IN, R & Z: 3/8" BSP

H: 1/2" BSP

Function Diagram:

0-204-0__

Material		Issue	Material Code No.
Changes		Date	Name
New Issue		08.01.2008	L.H.
New design of HC4- CV2-1 Valve Housing		04.02.2016	L.H.
			Hardening depth
			HV
Designer	Leif Hansen	Scale 1:2	HC4 Hydraulic Booster mounted with CV2 Valve Housing
Approved by	<i>Leif Hansen</i>	Format A3	
Date	03.02.2016		
Confidential: Property of miniBOOSTER HYDRAULICS A/S Denmark Not to be handed over to, copied or used by third party			
Assembly Drawing			Drawing No.: 0-355-02